



FD78-100

Drilling Unit

■ Specification

Hydraulic Pressure	20~45kg/cm ²
Drilling Capacity	φ 30(mild steel)
Power	1.5~3.7kw, 220V/380V
Max. Revolution/Minute	3,000rpm
Weight	175kg
Stroke	Hydraulic-50~100mm, Manual-50mm
Cylinder Diameter	φ 110
Cylinder Area	Forward 71.2cm ² , Backward 44.8cm ²
Thrust Force	2,136kg(30kg/cm ²)

■ Consumption Parts

Spindle Bearing	32008x1, 6008Zx1, 32007x1, 6007Zx1
Pulley Bearing	6013Zx2
O-Ring for Front Cover	DH-80x1, P-80x1, T601-80-90-6x1, G-105x3
O-Ring for Piston	P-100x2, G-65x1
O-Ring for Rear Cover	P55x1, T601-55-65-6x1, G-105x1

- This unit is mounted on a manual slide.
- Always use full hydraulic stroke.
- Stopper on spindle tail is not used.
- Suitable for higher RPM or high pressure.

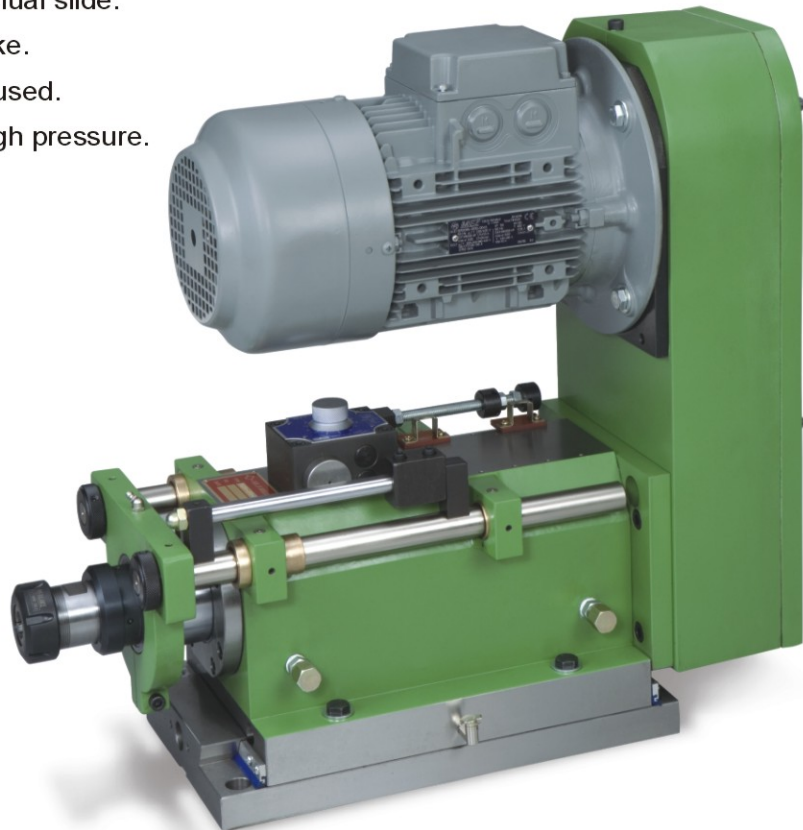



FD78-100

Drilling Unit

■ Dimensions

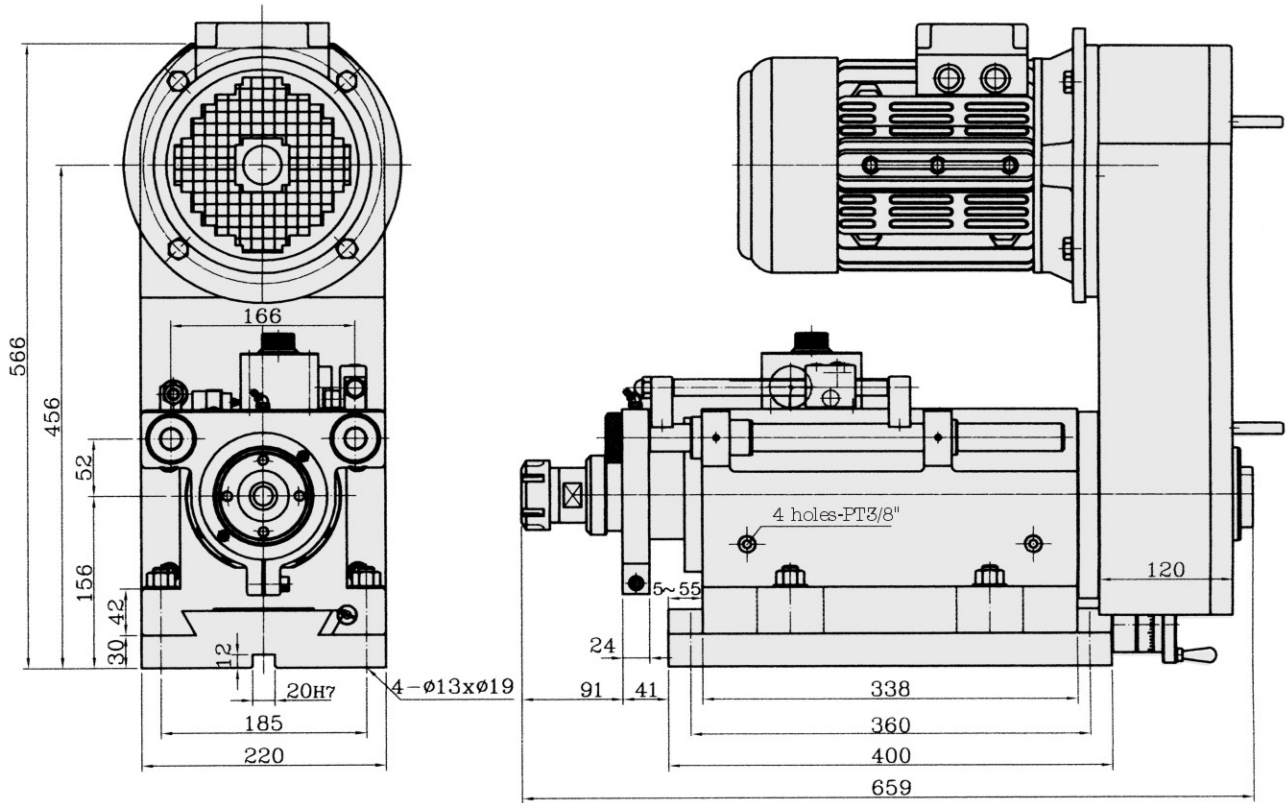

FD78-100-ER40

FD78-100-FB30

